

**POLY CHAIN® GT CARBON™**  
**ERO JOINT® AND ERO JOINT® ULTIMATE**

**ERO** JOINT

Without stopping your production line

**ASSEMBLE WITHOUT DISASSEMBLING**

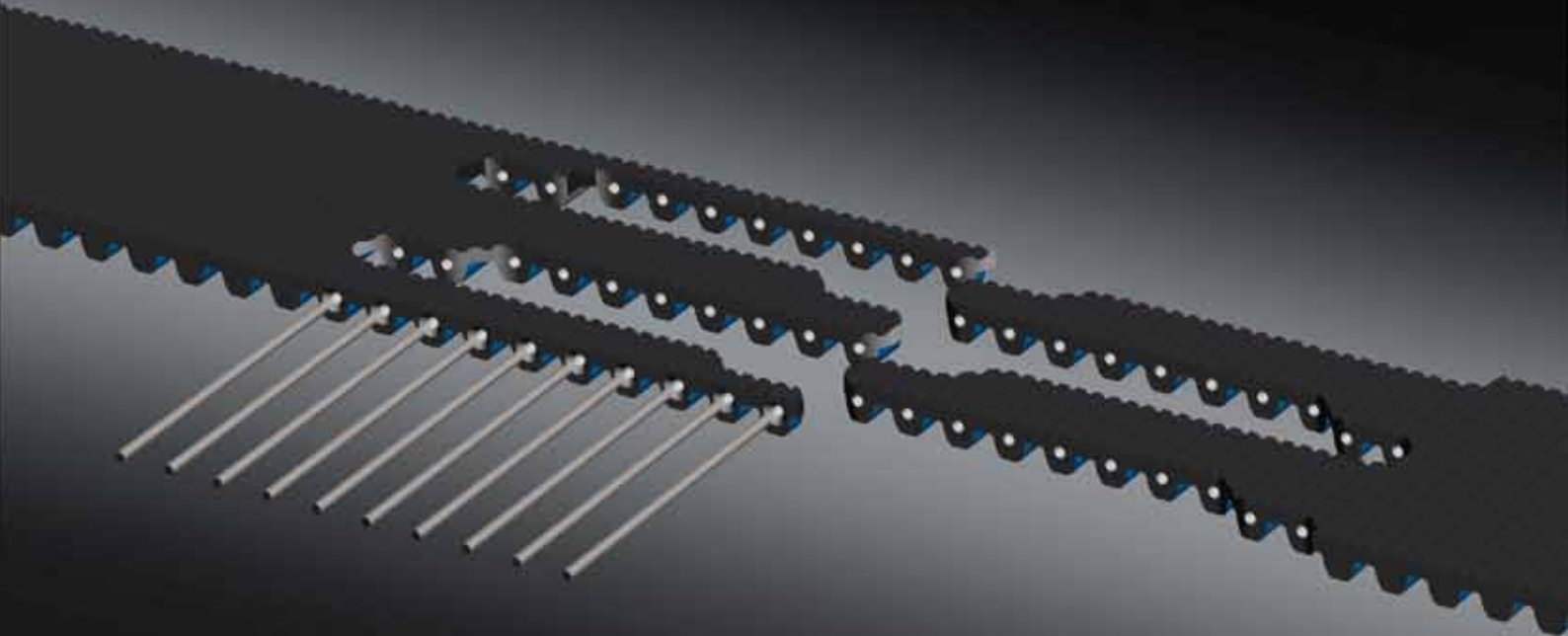

- Exclusive Gates and Tanals
- The only power transmission belt with mechanical assembly



## POLY CHAIN® GT CARBON™, THE BEST SYNCHRONOUS BELT

The use of high strength carbon fiber tension members and a new hard polyurethane compound makes the most powerful synchronous belt in the market.

Poly Chain® GT Carbon™ is a maintenance-free, energy saving belt which ensure very high transmission torque at low speed. It is an excellent alternative to roller chains and gear drives.

## POLY CHAIN® GT CARBON™ ERO JOINT®, THE SOLUTION OF BREAKDOWN IN TRANSMISSION BELT

The power of Gates combined with the know-how of Tanals. Poly Chain® GT Carbon™ outstanding mechanical performance combined to ERO Joint® provides the only existing transmission belt with mechanical assembly.

It allows to repair any installation initially fitted with HTD belts.

- A unique solution on the market
- Suitable for all HTD installations

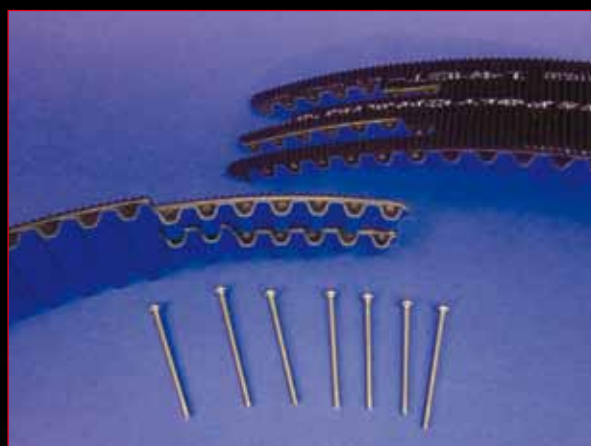

## COMPARISON OF TRANSMISSION TORQUES (IN NM)

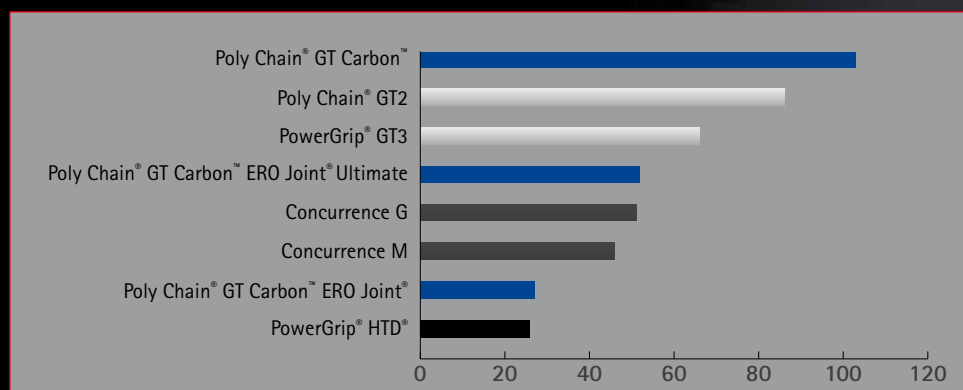

## ADVANTAGES

- Fast installation, no machinery disassembly (hoods, pulleys, axes, tensioners...).
- High mechanical resistance for a long-lasting repair. The Poly Chain® GT Carbon™ ERO Joint® Ultimate transmits half the power of a Poly Chain® GT Carbon™, more than a rubber belt.
- Optional set includes tools which make assembling easier and reduce assembly times.
- The only existing transmission belt with mechanical assembly.

- Workable in any length, can be adapted to any installation.
- Workable in any width superior or equal to 20 mm

## ERO JOINT® , ASSEMBLY SOLUTIONS

The ERO Joint® - developed by Tanals - provides various possibilities to assemble belts on-site without having to disassemble pulleys or axes and to release the transmission.

ERO Joint® and ERO joint® Ultimate are developed for and with Gates by Tanals. They offer unique solutions system for easy and fast repair of power transmission.

The cutting shapes of the junction fingers have been engineered for maximum tensile strength and fatigue resistance of the Poly Chain® GT Carbon™ material.

## POLY CHAIN® GT CARBON™ ERO JOINT® ULTIMATE, THE TRANSMISSION BELT WITH MECHANICAL ASSEMBLY

The power of Gates combined with the creativity of Tanals. Poly Chain® GT Carbon™ outstanding mechanical performance combined to patented innovative solution ERO Joint® Ultimate offers the only transmission belt with mechanical assembly whose performances equal those of all other endless belts on the market.

A lasting solution able to replace any rubber belt.  
(Can be fitted on HTD pulleys in case of breakdown).

- The only existing power transmission belt with mechanical assembly
- A sustainable solution able to replace any rubber belt

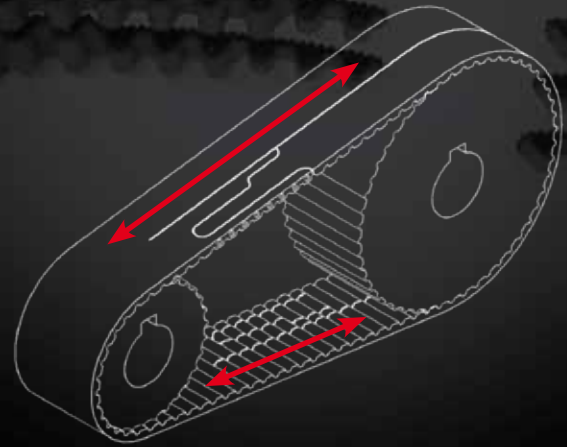

Always 1/2 continuous tight side: Junctions do not transmit stress,  
The mechanical resistance equals half that of a Poly Chain® GT Carbon™  
(Tanals Patent)

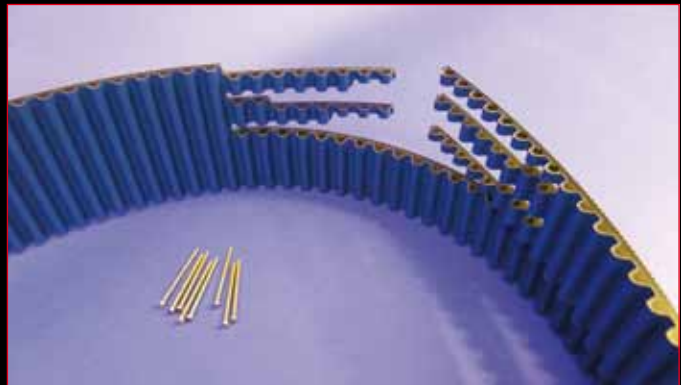

## PRODUCTIVITY GAINS

- Reduction of assembly times on car production lines:  
from 2 Hours to 15 min
- Reduction of assembly times on X-ray detectors in airports:  
from 8 Hours to 10 min

2h → 15 min  
8h → 10 min

## INSTALLATION TOOLS (OPTIONAL)

Though no specific equipments are required to assemble the belts, we recommend using our tools, which simplify the procedure and reduce downtimes even further.

### Description :

(1) Jaws for belt tension, (2) a barrel for stocking the pins, (3) a distributor linked to (4) a screw to insert and force the pins in the belt.

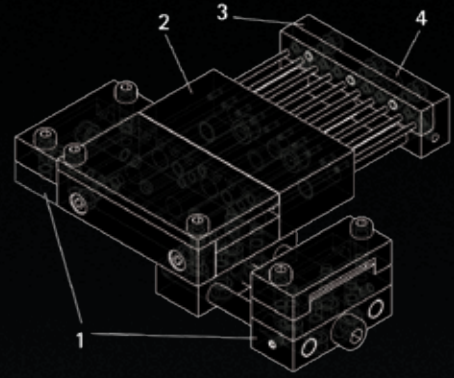

## ASSEMBLE WITHOUT DISASSEMBLING IN 3 STEPS

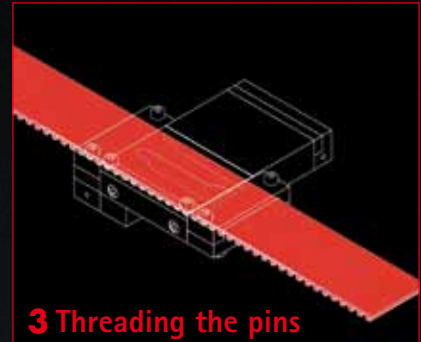
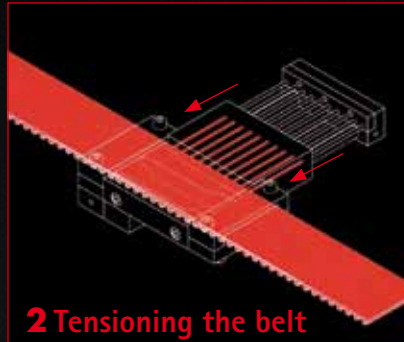
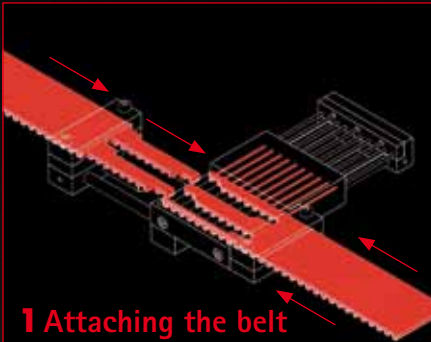

(Available in different versions: screw or pin assembling, with or without tension system)

## TOOL WITH PNEUMATIC JACK



## TONGUE



A tongue provided in each belt makes threading the belt around the pulleys easier



Your distributor:

For further information:

[www.ero-joint.com](http://www.ero-joint.com)

Phone: 00 33 (0)3 89 38 05 38



**ERO** JOINT

**TANALS**